

POM | KEPITAL ET-20S |

Grade

- KEPITAL ET-20S

Grade

		ISO 1043	-	POM-CD
(23 °C, 50 %RH)		ISO 62	%	-
		ISO 1183	g/cm ³	1.38
		ISO 1133	g/10min	11.5
(10 ⁴ /min)		ISO 11357		165
(1.8 MPa)		ISO 75		88
		UL 94	-	HB
		ISO 11359	X 10 ⁻⁵ /	-
		ISO 527	MPa	40
		ISO 527	%	4.0
		ISO 527	%	12
		ISO 178	MPa	67
		ISO 178	MPa	2,650
Charpy	(Notched, 23 °C)	ISO 179/1eA	kJ/m ²	4.0
		IEC 60093		1x10 ³
		IEC 60093	• cm	-
		IEC 60243-1	kV/mm	-
(, t = 2 mm)		ISO 294-4	%	1.9

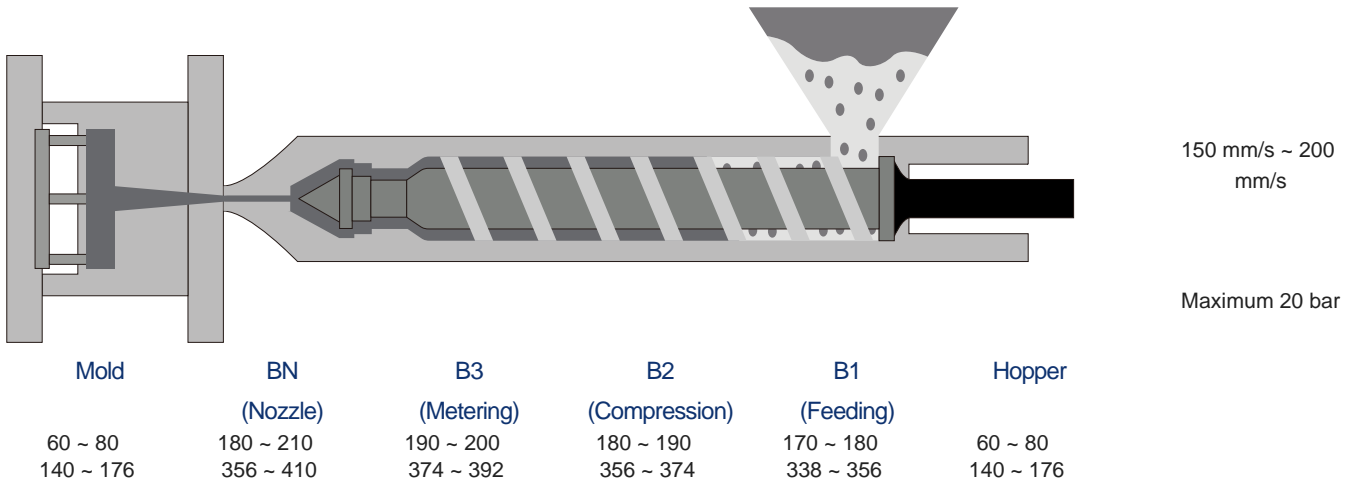

주소 : 230-30, T Tower 10 (04637) / Tel: 02-6952-8377
 연락처 : 94-15 (13901) / Tel: 031-436-1300

1. 가 가 () Implants
2. 가 가